

- a. 6" X 6" SLOT IN FLOOR FOR ELECTRIC SERVICE ENTRANCE TO C.B. PANEL ABOVE
- b. 2" X 2" X 1/4" MIN. ANCHOR CLIP WITH 3/4" ANCHOR BOLT HOLE, 4-REQ'D. AS SHOWN. ANCHOR BOOTH AFTER FINAL LOCATION. ANCHOR BOLTS NOT INCLUDED
- c. OUTER EDGE OF BASE

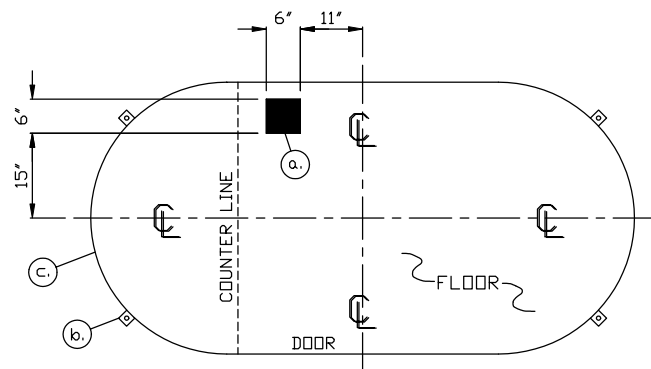

NOTE: PROVIDE 120/240V. 1Ø-3 WIRE SERVICE WITH GROUND. SERVICE ENTRANCE/ANCHOR BOLT LAYOUT

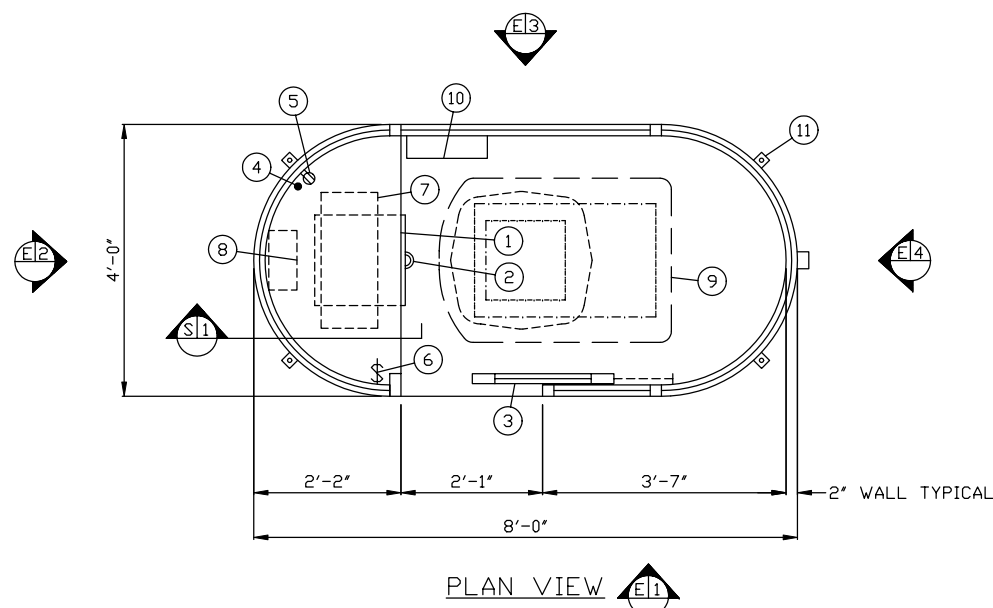

1. COUNTER- 24" DEEP PAINTED GALVANIZED STEEL 32" ABOVE FLOOR.
2. PAINTED STORAGE DRAWER BENEATH COUNTER.
3. DOOR- 25" WIDE, SLIDING STEEL WITH WEATHER-STRIPPING, BALL BEARING HANGERS, SAFETY GLAZING, CASHIER WINDOW, HEAVY DUTY TRACK, LOCK, & HARDWARE.
4. 1-1/4" HOLE IN COUNTER FOR DROP CORDS TO OUTLET.
5. DUPLEX OUTLET- MOUNTED BELOW COUNTER.
6. LIGHT SWITCH MOUNTED ABOVE COUNTER FOR INTERIOR LIGHT.
7. LIGHT- 2-20 WATT FLUORESCENT RECESSED LIGHT FIXTURE WITH LENS.
8. HEATER- 120V./1,500 WATT FAN FORCED WITH INTEGRAL THERMOSTAT CONTROL.
9. AIR CONDITIONER- 120V./13,500 BTU ROOF MOUNTED WITH INTEGRAL THERMOSTAT CONTROL.
10. C.B. PANEL- 12 SPACE 120/240V. 1Ø-3 WIRE WITH GROUND BAR. 100 AMP MAIN BREAKER IS INCLUDED.
11. ANCHOR CLIP- 2" X 2" X 1/4" MIN. STEEL WELDED TO BASE AT GRADE WITH 3/4" ANCHOR BOLT HOLE. 4-REQ'D. ANCHOR BOOTH AFTER FINAL LOCATION. ANCHOR BOLTS NOT INCLUDED.

NOTE: PAR-KUT BOOTHS ARE OF SINGLE UNIT WELDED GALVANIZED STEEL CONSTRUCTION, FACTORY ASSEMBLED AND DELIVERED SET UP. FAILURE TO SECURELY ANCHOR BOOTH MAY RESULT IN OVERTURNING OF UNIT AND SERIOUS INJURY TO OCCUPANT.

- A. GLAZING TO BE 3/16" CLEAR POLYCARBONATE SAFETY GLAZING IN CURVED ENDS ONLY AND 1/4" CLEAR TEMPERED SAFETY GLAZING IN FLAT SIDES ONLY. ALL WINDOWS TO HAVE STEEL EXTERIOR GLAZING STOPS AND ALUMINUM INTERIOR GLAZING STOPS.
- B. PAINT- A RUST INHIBITIVE PRIMER WITH AN INDUSTRIAL FINISH.
- C. ELECTRICAL- ALL WIRING BY PAR-KUT TO BE #12(MIN) STRANDED COPPER, THHN ENCLOSED IN 1/2"(MIN) E.M.T. PER NATIONAL ELECTRIC CODE. FITTINGS, FIXTURES & DEVICES ARE U.L. LABELED. ALL WIRING TO TERMINATE AT C.B. PANEL. ALL CIRCUITS HAVE GREEN GROUND WIRE.
- D. BOOTH WILL NOT HAVE A CANOPY OVERHANG.
- E. LIFTING RING(S) ARE PROVIDED IN ROOF.
- F. NO ON SITE WORK BY PAR-KUT.

NOTE: THIS PRINT AND DESIGN ARE THE PROPERTY OF PAR-KUT INTERNATIONAL, INC. IT MUST NOT BE REPRODUCED IN ANY MANNER, NOR SHALL IT BE SUBMITTED TO OUTSIDE PARTIES FOR EXAMINATION WITHOUT OUR CONSENT. IT SHALL BE USED ONLY AS A MEANS OF REFERENCE TO WORK DESIGNED AND FURNISHED BY PAR-KUT. PAR-KUT RESERVES THE RIGHT TO MAKE CHANGES TO DESIGN FOR ENGINEERING PURPOSES WITHOUT NOTICE. REVISIONS MAY NOT BE NOTED.

PAR-KUT INTERNATIONAL, INC.
40961 Production Drive
Harrison Twp, Mich.
48045-1351
PH. (810) 468-2947

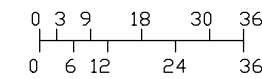

SCALE BAR
NOTE: ELEVATIONS 2:1

DWG# 2K283 SHEET A-1

MISTER CAR WASH
HOUSTON, TX

A/E NOTES
PAINT COLOR: WHITE

PD# 2-636	DRAWN BY AJP	REVISED 5-12-2000
SCALE NTS	SIZE 4' X 8'	QTY 1
DATE 4-21-2000	SALES REPRESENTATIVE TOM DUEMLING	