

NOTE: PROVIDE 480/277V, 3Ø-4 WIRE SERVICE WITH GROUND.
SERVICE ENTRANCE/ANCHOR BOLT LAYOUT

FLOOR HOLE SCHEDULE

- a. 4" X 31" SLOT IN FLOOR FOR ELECTRIC SERVICE ENTRANCE TO C.B. PANELS ABOVE.
- b. 4" X 9" SLOT IN FLOOR
- c. 10" X 36" SLOT IN FLOOR
- d. 3" X 3" X 1/4" MIN. ANCHOR CLIP WITH 1" ANCHOR BOLT HOLE, 4-REQ'D. ONE EACH CORNER. ANCHOR BOOTH AFTER FINAL LOCATION. ANCHOR BOLTS NOT INCLUDED
- e. OUTER EDGE OF BASE

A.D.A. NOTE
BOOTH MUST BE HANDICAP ACCESSIBLE. THE FOUNDATION MAY BE RECESSED OR A 1:12 RAMP MUST BE PROVIDED SO THAT MAXIMUM CHANGE IN LEVEL FROM GRADE TO FINISH FLOOR DOES NOT EXCEED 1/4"

1. COUNTER- 22" DEEP STAINLESS STEEL 304 #3 FINISH WITH 4" BACKSLASH, 32" ABOVE FINISH FLOOR.
2. STORAGE DRAWER BENEATH COUNTER WITH STAINLESS STEEL FACE.
3. DOOR- 36" WIDE, SLIDING STEEL WITH WEATHER-STRIPPING, BALL BEARING HANGERS, SAFETY GLAZING, HEAVY DUTY TRACK, HOOK BOLT LOCK, & BEST CYLINDERS HARDWARE, 3-REQ'D.
4. PRIVACY DOOR- 36" WIDE, SLIDING ALUMINUM WITH INSIDE LOCK.
5. 1-1/4" HOLE IN COUNTER FOR DROP CORDS, 4-REQ'D.
6. DUPLEX OUTLET- MOUNTED ABOVE COUNTER, 8-REQ'D.
7. GROUND FAULT INTERRUPT RECEPTACLE MOUNTED IN REST ROOM.
8. PHONE JACK MOUNTED BELOW COUNTER WITH RACEWAY TO JUNCTION BOX NEAR FLOOR SLOT, 4-REQ'D.
9. LIGHT SWITCH FOR INTERIOR OFFICE LIGHTS.
10. LIGHT- 2-34 WATT LAMP FLUORESCENT LIGHT FIXTURE WITH LENS, 3-REQ'D.
11. SWITCH FOR COMBINATION HEAT/LIGHT/AND EXHAUST FAN IN REST ROOM.
12. WALL MOUNTED THERMOSTAT CONTROL FOR COMBINATION HEAT/LIGHT/EXHAUST FAN IN REST ROOM.
13. COMBINATION HEAT/LIGHT/EXHAUST FAN 70 CFM, MOUNTED IN REST ROOM CEILING.
14. WALL MOUNTED THERMOSTAT CONTROL FOR HEATER MOUNTED UNDER COUNTER, 2-REQ'D.
15. HEATER- 240V./4,000 WATT FAN FORCED WITH WALL MOUNTED THERMOSTAT CONTROL, 2-REQ'D.
16. WALL MOUNTED THERMOSTAT CONTROL FOR AIR CONDITIONER UNIT, 2-REQ'D.
17. RP-607-1 C.B. PANEL- 24 SPACE 120/240V, 1Ø-3 WIRE WITH GROUND BAR. 125 AMP MAIN BREAKER IS INCLUDED. BREAKER PROVIDED FOR ALL FACTORY WIRED CIRCUITS.
18. LP-607-1 C.B. PANEL- 18 SPACE 480/277V, 3Ø-4 WIRE WITH GROUND BAR. 100 AMP MAIN BREAKER IS INCLUDED, 1 - 3P/30A. AND 1 - 2P/70A. SPARE BREAKERS PROVIDED. NO OTHER SPARE BREAKERS PROVIDED BY PAR-KUT. (THIS PANEL IS PROVIDED FOR CUSTOMER USE ONLY)
19. ANCHOR CLIP- 3" X 3" X 1/4" MIN. STEEL WELDED TO BASE AT GRADE WITH 1" ANCHOR BOLT HOLE. 4-REQ'D. ANCHOR BOOTH AFTER FINAL LOCATION. ANCHOR BOLTS NOT INCLUDED.
20. MIRROR MOUNTED ABOVE LAVATORY.
21. COAT HOOK MOUNTED ON WALL.
22. STAINLESS STEEL SPLASH GUARD.
23. STAINLESS STEEL ADA GRAB BAR, 2-REQ'D.
24. GROUND FAULT INTERRUPT RECEPTACLE MOUNTED IN REST ROOM FOR WATER HEATER.

NOTE: THE FOLLOWING ITEMS ARE SHIPPED LOOSE CARTONS AND FIELD INSTALLED AT SITE BY OTHERS.

25. AIR CONDITIONER 120V./13,500 BTU ROOF MOUNTED WITH WALL MOUNTED THERMOSTAT CONTROL.
26. LOCKING TWO DRAWER FILE CABINET.
27. WHITE CHINA LAVATORY WITH CHROME TRIM.
28. WHITE CHINA WATER CLOSET WITH OPEN FRONT SEAT.
29. WATER HEATER- ARISTON 2-1/2 GALLON POINT OF USE.

NOTE: PAR-KUT BOOTHS ARE OF SINGLE UNIT WELDED GALVANIZED STEEL CONSTRUCTION, FACTORY ASSEMBLED AND DELIVERED SET UP. FAILURE TO SECURELY ANCHOR BOOTH MAY RESULT IN OVERTURNING OF UNIT AND SERIOUS INJURY TO OCCUPANT.

- A. GLAZING TO BE TINTED INSULATED SAFETY GLAZING SET IN ANODIZED ALUMINUM WINDOW FRAMES.
- B. PAINT- A RUST INHIBITIVE PRIMER WITH AN INDUSTRIAL FINISH.
- C. ELECTRICAL- ALL WIRING BY PAR-KUT TO BE #12(MIN) STRANDED COPPER, THHN ENCLOSED IN 1/2"(MIN) E.M.T. PER NATIONAL ELECTRIC CODE. FITTINGS, FIXTURES & DEVICES ARE U.L. LABELED. ALL WIRING TO TERMINATE AT C.B. PANEL ITEM #17. ALL CIRCUITS HAVE GREEN GROUND WIRE.
- D. CANOPY OVERHANG BY OTHERS.
- E. LIFTING RING(S) ARE PROVIDED IN ROOF.
- F. NO ON SITE WORK BY PAR-KUT.

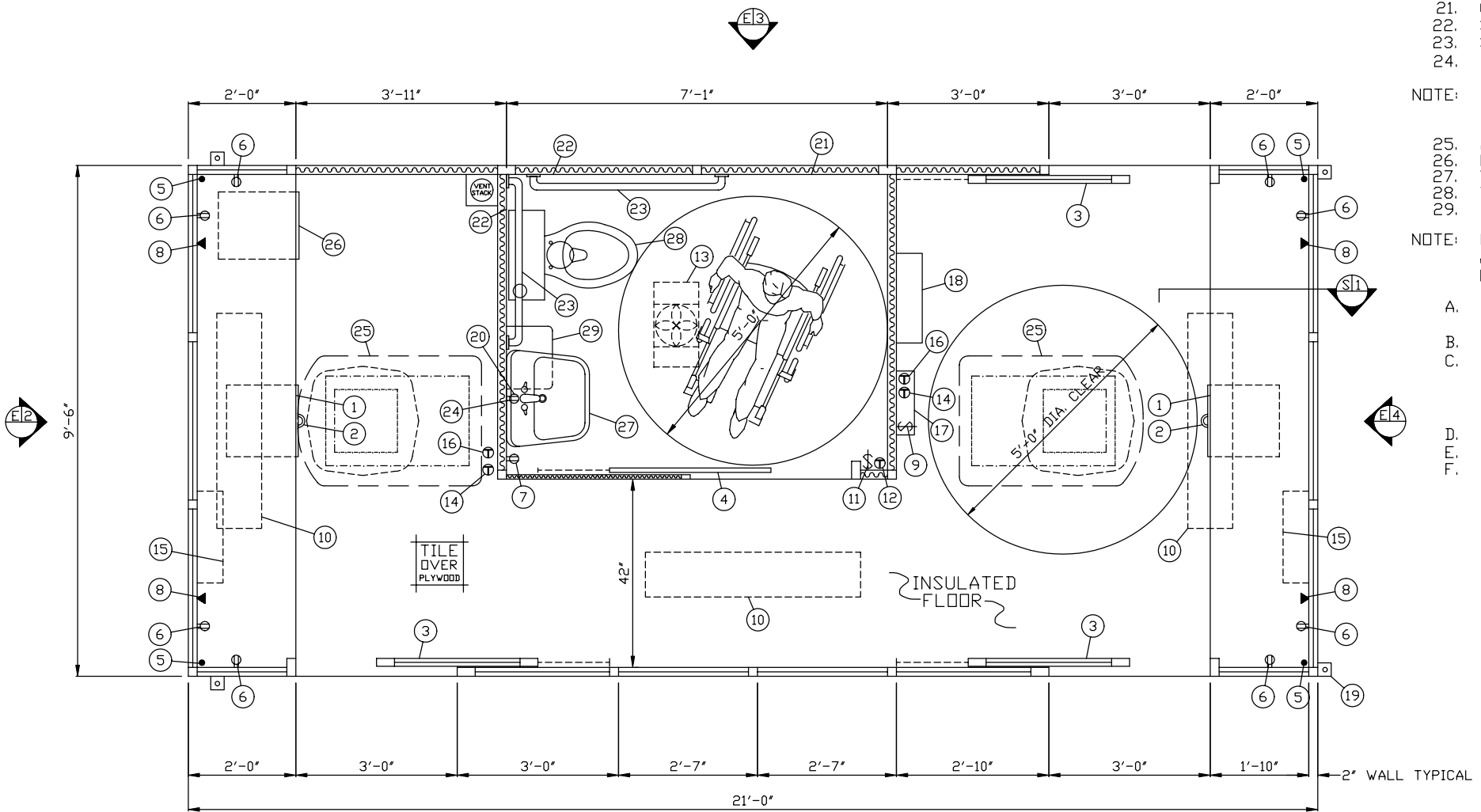

PLAN VIEW

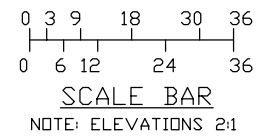

NOTE: THIS PRINT AND DESIGN ARE THE PROPERTY OF PAR-KUT INTERNATIONAL, INC. IT MUST NOT BE REPRODUCED IN ANY MANNER, NOR SHALL IT BE SUBMITTED TO OUTSIDE PARTIES FOR EXAMINATION WITHOUT OUR CONSENT. IT SHALL BE USED ONLY AS A MEANS OF REFERENCE TO WORK DESIGNED AND FURNISHED BY PAR-KUT. PAR-KUT RESERVES THE RIGHT TO MAKE CHANGES TO DESIGN FOR ENGINEERING PURPOSES WITHOUT NOTICE. REVISIONS MAY NOT BE NOTED.

Design Codes:
675 IAC 13-2.3 Indiana Building Code, effective 4-30-98, amended 8-28-99 and 2-25-00
675 IAC 16-1.3 Indiana Plumbing Code, effective 7-30-99
675 IAC 18-1.3 Indiana Mechanical Code, effective 1-23-98
675 IAC 17-1.5 1999 Indiana Electrical Code, effective 2-12-00

PAR-KUT INTERNATIONAL, INC.
40961 Production Drive
Harrison Twp, Mich.
48045-1351
PH. (810) 468-2947

DWG# 01-447 SHEET A-1

A/E NOTES
PAINT COLOR: PPG CODE 5MA98898 TOYOTA GRAY
TINTED GLAZING COLOR: GRAY
(VCT) TILE COLOR: SHADOW BLUE #51807

TOYOTA MOTOR MANUFACTURING
DEIG CONSTRUCTION
PRINCETON, IN

DATE	SIZE	REVISED
10-26-2001	9'-6" X 21'	1-31-2002 DLT
CHK'D BY:	SALES REPRESENTATIVE	QTY
	JIM SMITH	1

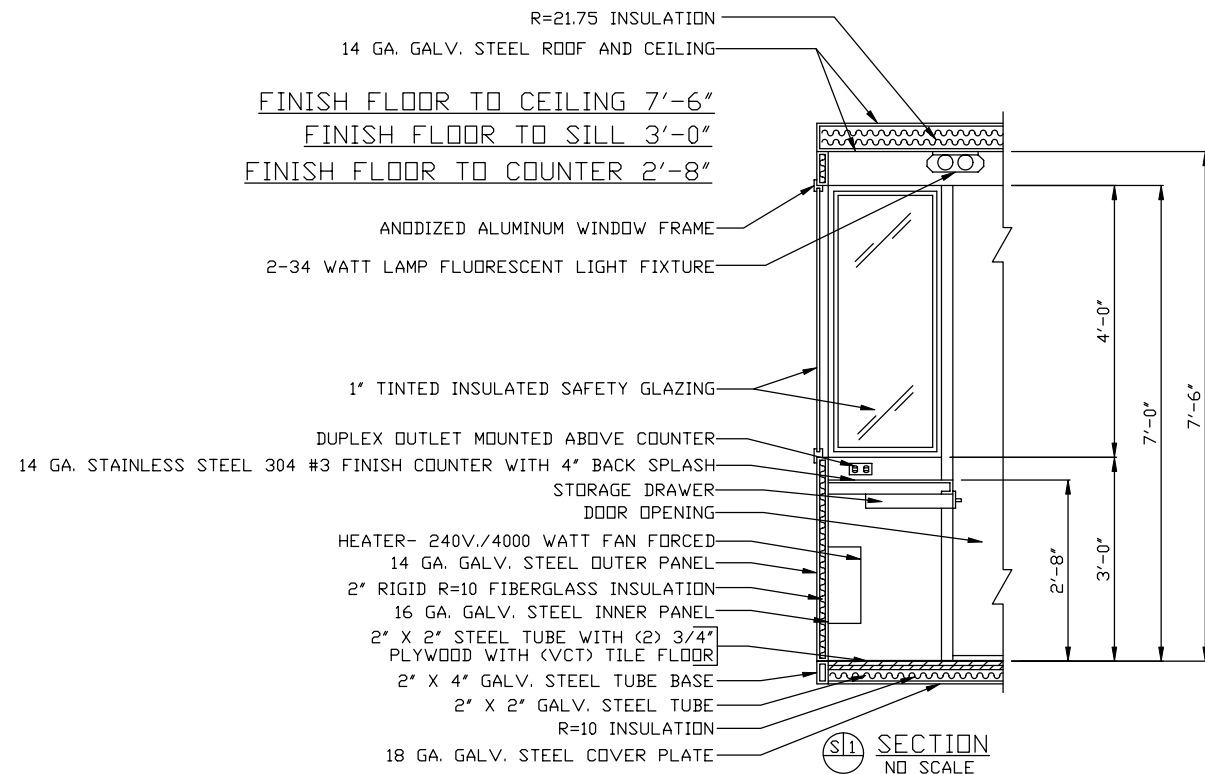
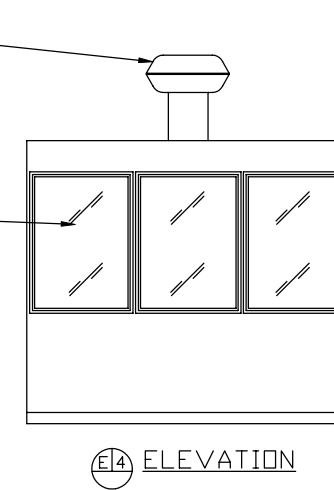
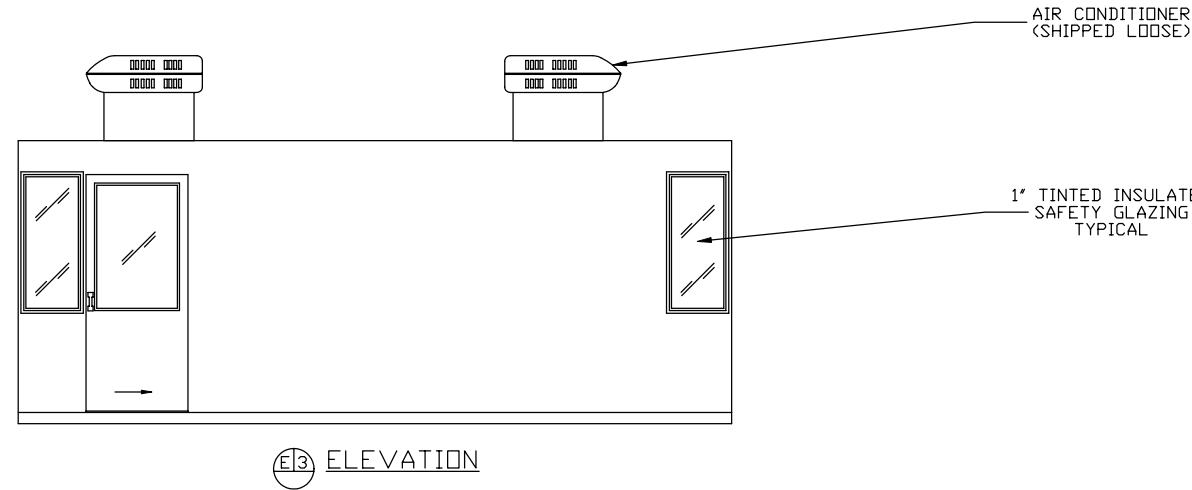
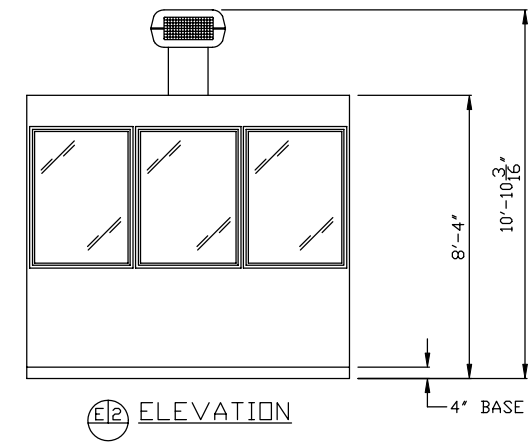
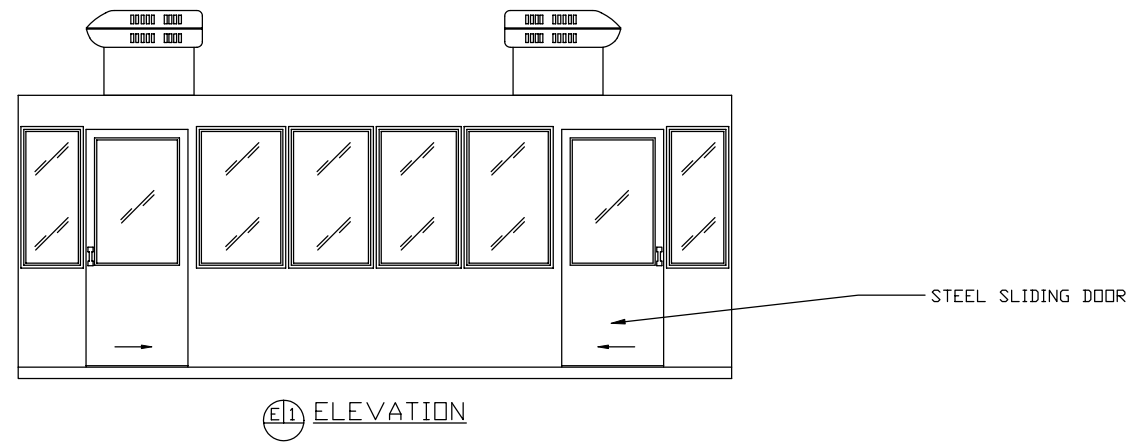

A.D.A. NOTE
BOOTH MUST BE HANDICAP ACCESSIBLE. THE FOUNDATION MAY BE RECESSED OR A 1:12 RAMP MUST BE PROVIDED SO THAT MAXIMUM CHANGE IN LEVEL FROM GRADE TO FINISH FLOOR DOES NOT EXCEED 1/4"

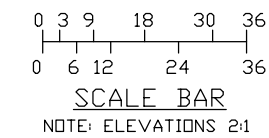

NOTE: THIS PRINT AND DESIGN ARE THE PROPERTY OF PAR-KUT INTERNATIONAL, INC. IT MUST NOT BE REPRODUCED IN ANY MANNER, NOR SHALL IT BE SUBMITTED TO OUTSIDE PARTIES FOR EXAMINATION WITHOUT OUR CONSENT. IT SHALL BE USED ONLY AS A MEANS OF REFERENCE TO WORK DESIGNED AND FURNISHED BY PAR-KUT. PAR-KUT RESERVES THE RIGHT TO MAKE CHANGES TO DESIGN FOR ENGINEERING PURPOSES WITHOUT NOTICE. REVISIONS MAY NOT BE NOTED.

PAR-KUT INTERNATIONAL, INC.
40961 Production Drive
Harrison Twp, Mich.
48045-1351
PH. (810) 468-2947



DWG#	01-447	SHEET	A-2
TOYOTA MOTOR MANUFACTURING DEIG CONSTRUCTION PRINCETON, IN			
PN#	VERBAL	SCALE	NTS
DRAWN BY	AJP	REVISED	1-31-2002 DLT
DATE	10-26-2001	SIZE	9'-6" X 21'
CHK'D BY:		QTY	1
		SALES REPRESENTATIVE JIM SMITH	