

- a. 2" X 2" X 1/4" MIN. ANCHOR CLIP WITH 3/4" ANCHOR BOLT HOLE, 4-REQ'D. ONE EACH CORNER.
- * ANCHOR BOOTH AFTER FINAL LOCATION. ANCHOR BOLTS NOT INCLUDED
- b. OUTER EDGE OF BASE

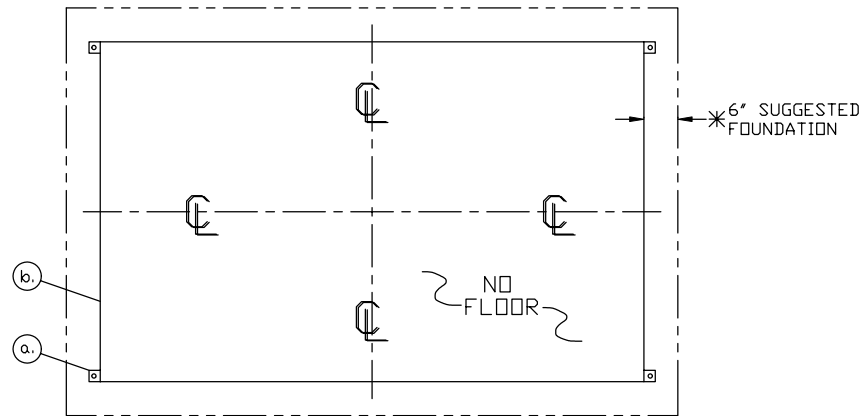

NOTE: PROVIDE 120/240V. 1Ø-3 WIRE SERVICE WITH GROUND.
ANCHOR BOLT LAYOUT

1. BENCH 6 FOOT LONG MADE OF RECYCLED PLASTIC "CEDAR COLOR" MOUNTED 20" ABOVE GRADE. SHIPPED LOOSE AND INSTALLED BY OTHERS ON SITE.
2. KENALL LIGHT- 2-34 WATT LAMP FLUORESCENT LIGHT FIXTURE WITH 0° BALLAST, VANDAL RESISTANT LENS AND PHOTO CELL.
3. HEATER- 240V./4,000 WATT FAN FORCED WITH INTEGRAL TAMPER RESISTANT THERMOSTAT CONTROL.
8. WEATHER TIGHT C.B. PANEL- 8 SPACE 120/240V. 1Ø-3 WIRE WITH GROUND BAR. 60 AMP BACK FED MAIN BREAKER IS INCLUDED.
9. ANCHOR CLIP- 2" X 2" X 1/4" MIN. STEEL WELDED TO BASE AT GRADE WITH 3/4" ANCHOR BOLT HOLE. 4-REQ'D. * ANCHOR BOOTH AFTER FINAL LOCATION. ANCHOR BOLTS NOT INCLUDED.

NOTE: PAR-KUT BOOTHS ARE OF SINGLE UNIT WELDED GALVANIZED STEEL CONSTRUCTION, FACTORY ASSEMBLED AND DELIVERED SET UP. FAILURE TO SECURELY ANCHOR BOOTH MAY RESULT IN OVERTURNING OF UNIT AND SERIOUS INJURY TO OCCUPANT.

- A. GLAZING TO BE CLEAR TEMPERED SAFETY GLAZING SET IN ANODIZED ALUMINUM WINDOW FRAMES.
- B. PAINT- A RUST INHIBITIVE PRIMER WITH AN INDUSTRIAL FINISH.
- C. ELECTRICAL- ALL WIRING BY PAR-KUT TO BE #12(MIN) STRANDED COPPER, THHN ENCLOSED IN 1/2"(MIN) E.M.T. PER NATIONAL ELECTRIC CODE. FITTINGS, FIXTURES & DEVICES ARE U.L. LABELED. ALL WIRING TO TERMINATE AT C.B. PANEL. ALL CIRCUITS HAVE GREEN GROUND WIRE.
- D. BOOTH WILL HAVE A 2" CANOPY OVERHANG ON ALL SIDES.
- E. NO LIFTING RING(S) ARE PROVIDED IN ROOF.
- F. NO ON SITE WORK BY PAR-KUT.

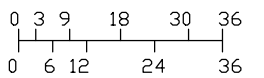

SCALE BAR

NOTE: ELEVATIONS 2:1

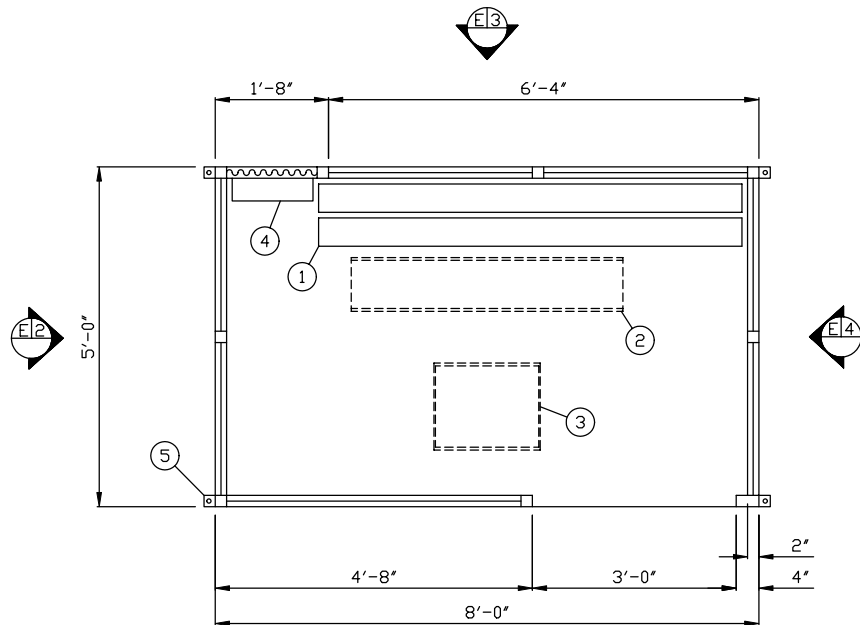

PLAN VIEW

* LIGHTING SHALL BE PROVIDED ON SITE FOR EXIT DISCHARGE PER OBC 1003.2.11.2

* ALL ITEMS MARKED WITH AN ASTERISK ARE FIELD WORK ITEMS AND ARE NOT PART OF THE INDUSTRIALIZED UNIT APPROVAL.

* FIELD WORK

- * CONCRETE FOUNDATION
- * ANCHORING UNIT IN PLACE
- * ELECTRICAL CONNECTION TO SERVICE PANEL
- * GROUNDING ELECTRODE
- * ANCHOR BOLTS
- * INSTALLATION OF ALL PLUMBING PIPE, FITTING AND FIXTURES
- * PIPE & FITTING PROVIDE BY OTHERS

NOTE: THIS PRINT AND DESIGN ARE THE PROPERTY OF PAR-KUT INTERNATIONAL, INC. IT MUST NOT BE REPRODUCED IN ANY MANNER, NOR SHALL IT BE SUBMITTED TO OUTSIDE PARTIES FOR EXAMINATION WITHOUT OUR CONSENT. IT SHALL BE USED ONLY AS A MEANS OF REFERENCE TO WORK DESIGNED AND FURNISHED BY PAR-KUT. PAR-KUT RESERVES THE RIGHT TO MAKE CHANGES TO DESIGN FOR ENGINEERING PURPOSES WITHOUT NOTICE. REVISIONS MAY NOT BE NOTED.

PAR-KUT INTERNATIONAL, INC.
40961 Production Drive
Harrison Twp, Mich.
48045-1351
PH. (586) 468-2947



DWG# 02-516-19 SHEET A-1

DAYTON INTERNATIONAL AIRPORT
REPUBLIC PARKING
DAYTON, OH

GENERAL NOTES

PAINT COLOR: _____
(PLEASE SPECIFY COLOR)

SCALE	NTS	DRAWN BY	AJP	REVISED
DATE	10-16-2002	SIZE	5' x 8'	QTY
CHK'D BY:				4
				SALES REPRESENTATIVE JIM SMITH